

# 2枚刃 ボールエンドミル

## 2-Flute Ball End Mill

# ABES-2

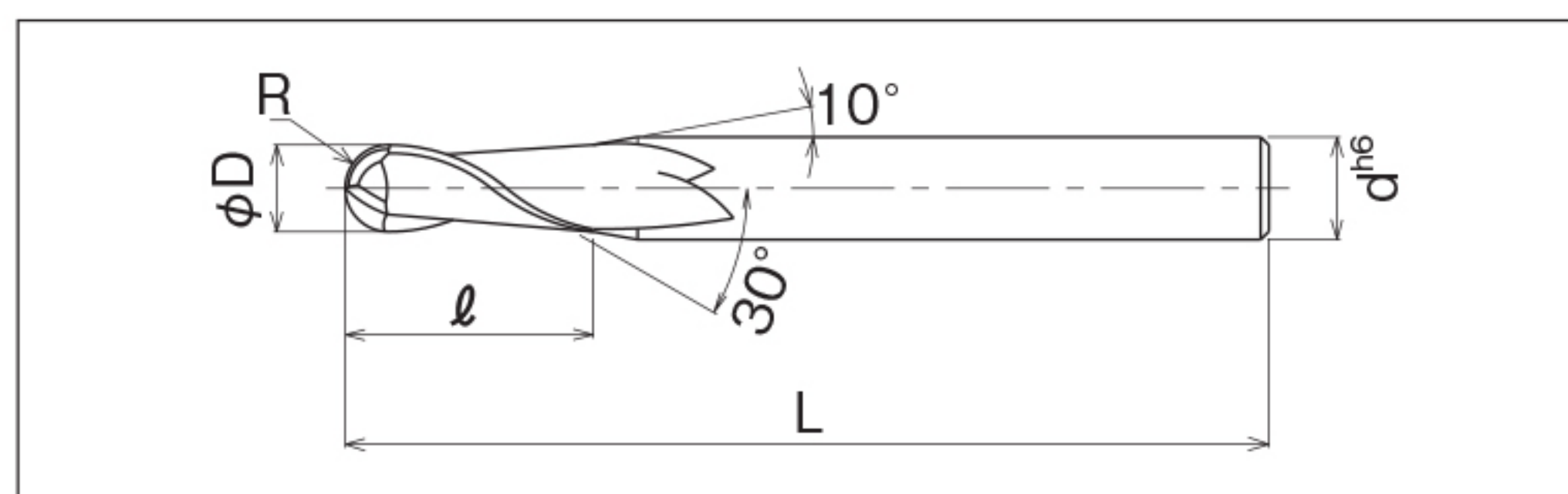

■ 一般鋼材から非鉄、樹脂まで幅広い適用が可能です。

Wide application available in work materials, from general steel to non-ferrous and resin.

■ ノンコート of シャープな切れ味が高精度、高品位な仕上げ面を実現します。

Uncoated sharp cutting edge realize high precision and fine surface finish.

外径公差：+0/-0.02 R公差：±0.01

φD Tolerance

R Tolerance



単位 Unit : mm

型番 CODE NUMBER	R	径 φD	刃長 ℓ	全長 L	シャンク d	定価 ¥
ABES-20100	0.5	1.0	3	40	4	
ABES-20110	0.55	1.1	3	40	4	
ABES-20120	0.6	1.2	3	40	4	
ABES-20130	0.65	1.3	3	40	4	
ABES-20140	0.7	1.4	3	40	4	
ABES-20150	0.75	1.5	5	40	4	
ABES-20160	0.8	1.6	5	40	4	
ABES-20170	0.85	1.7	5	40	4	
ABES-20180	0.9	1.8	5	40	4	
ABES-20190	0.95	1.9	5	40	4	
ABES-20200	1	2.0	6	40	4	
ABES-20210	1.05	2.1	6	40	4	
ABES-20220	1.1	2.2	6	40	4	
ABES-20230	1.15	2.3	6	40	4	
ABES-20240	1.2	2.4	6	40	4	
ABES-20250	1.25	2.5	8	40	4	
ABES-20260	1.3	2.6	8	40	4	
ABES-20270	1.35	2.7	8	40	4	
ABES-20280	1.4	2.8	8	40	4	
ABES-20290	1.45	2.9	8	40	4	
ABES-20300	1.5	3.0	8	45	4	
ABES-20310	1.55	3.1	8	45	4	
ABES-20320	1.6	3.2	8	45	4	
ABES-20330	1.65	3.3	8	45	4	
ABES-20340	1.7	3.4	8	45	4	
ABES-20350	1.75	3.5	10	45	4	
ABES-20360	1.8	3.6	10	45	4	

型番 CODE NUMBER	R	径 φD	刃長 ℓ	全長 L	シャンク d	定価 ¥
ABES-20370	1.85	3.7	10	45	4	
ABES-20380	1.9	3.8	10	45	4	
ABES-20390	1.95	3.9	10	45	4	
ABES-20400	2	4.0	12	45	6	
ABES-20410	2.05	4.1	12	45	6	
ABES-20420	2.1	4.2	12	45	6	
ABES-20430	2.15	4.3	12	45	6	
ABES-20440	2.2	4.4	12	45	6	
ABES-20450	2.25	4.5	12	45	6	
ABES-20460	2.3	4.6	12	45	6	
ABES-20470	2.35	4.7	12	45	6	
ABES-20480	2.4	4.8	12	45	6	
ABES-20490	2.45	4.9	12	45	6	
ABES-20500	2.5	5.0	15	60	6	
ABES-20510	2.55	5.1	15	60	6	
ABES-20520	2.6	5.2	15	60	6	
ABES-20530	2.65	5.3	15	60	6	
ABES-20540	2.7	5.4	15	60	6	
ABES-20550	2.75	5.5	15	60	6	
ABES-20560	2.8	5.6	15	60	6	
ABES-20570	2.85	5.7	15	60	6	
ABES-20580	2.9	5.8	15	60	6	
ABES-20590	2.95	5.9	15	60	6	
ABES-20600	3	6.0	15	60	6	
ABES-20610	3.05	6.1	15	60	6	
ABES-20620	3.1	6.2	15	60	6	
ABES-20630	3.15	6.3	15	60	6	

Next

# ABES-2 2枚刃 ボールエンドミル

単位 Unit : mm

型番 CODE NUMBER	R	径 φD	刃長 ℓ	全長 L	シャンク d	定価 ¥
ABES-20635	3.175	6.35	15	60	6	
ABES-20640	3.2	6.4	15	60	6	
ABES-20650	3.25	6.5	15	60	6	
ABES-20660	3.3	6.6	15	60	6	
ABES-20670	3.35	6.7	15	60	6	
ABES-20680	3.4	6.8	15	60	6	
ABES-20690	3.45	6.9	15	60	6	
ABES-20700	3.5	7.0	20	60	8	
ABES-20710	3.55	7.1	20	60	8	
ABES-20720	3.6	7.2	20	60	8	
ABES-20730	3.65	7.3	20	60	8	
ABES-20740	3.7	7.4	20	60	8	
ABES-20750	3.75	7.5	20	60	8	
ABES-20760	3.8	7.6	20	60	8	
ABES-20770	3.85	7.7	20	60	8	
ABES-20780	3.9	7.8	20	60	8	
ABES-20790	3.95	7.9	20	60	8	
ABES-20800	4	8.0	20	60	8	
ABES-20810	4.05	8.1	20	60	8	
ABES-20820	4.1	8.2	20	60	8	
ABES-20830	4.15	8.3	20	60	8	
ABES-20840	4.2	8.4	20	60	8	
ABES-20850	4.25	8.5	20	60	8	
ABES-20860	4.3	8.6	20	60	8	
ABES-20870	4.35	8.7	20	60	8	
ABES-20880	4.4	8.8	20	60	8	
ABES-20890	4.45	8.9	20	60	8	
ABES-20900	4.5	9.0	20	70	10	
ABES-20910	4.55	9.1	20	70	10	
ABES-20920	4.6	9.2	20	70	10	
ABES-20930	4.65	9.3	20	70	10	
ABES-20940	4.7	9.4	20	70	10	
ABES-20950	4.75	9.5	20	70	10	
ABES-20960	4.8	9.6	20	70	10	
ABES-20970	4.85	9.7	20	70	10	
ABES-20980	4.9	9.8	20	70	10	
ABES-20990	4.95	9.9	20	70	10	
ABES-21000	5	10.0	25	70	10	
ABES-21010	5.05	10.1	25	70	10	
ABES-21020	5.1	10.2	25	70	10	
ABES-21030	5.15	10.3	25	70	10	
ABES-21040	5.2	10.4	25	70	10	
ABES-21050	5.25	10.5	25	70	10	
ABES-21060	5.3	10.6	25	70	10	

型番 CODE NUMBER	R	径 φD	刃長 ℓ	全長 L	シャンク d	定価 ¥
ABES-21070	5.35	10.7	25	70	10	
ABES-21080	5.4	10.8	25	70	10	
ABES-21090	5.45	10.9	25	70	10	
ABES-21100	5.5	11.0	25	75	12	
ABES-21110	5.55	11.1	25	75	12	
ABES-21120	5.6	11.2	25	75	12	
ABES-21130	5.65	11.3	25	75	12	
ABES-21140	5.7	11.4	25	75	12	
ABES-21150	5.75	11.5	25	75	12	
ABES-21160	5.8	11.6	25	75	12	
ABES-21170	5.85	11.7	25	75	12	
ABES-21180	5.9	11.8	25	75	12	
ABES-21190	5.95	11.9	25	75	12	
ABES-21200	6	12.0	25	75	12	
ABES-21210	6.05	12.1	25	75	12	
ABES-21220	6.1	12.2	25	75	12	
ABES-21230	6.15	12.3	25	75	12	
ABES-21240	6.2	12.4	25	75	12	
ABES-21250	6.25	12.5	25	75	12	
ABES-21260	6.3	12.6	25	75	12	
ABES-21270	6.35	12.7	25	75	12	
ABES-21280	6.4	12.8	25	75	12	
ABES-21290	6.45	12.9	25	75	12	
ABES-21300	6.5	13.0	30	80	12	
ABES-21350	6.75	13.5	30	80	12	
ABES-21360	6.8	13.6	30	80	12	
ABES-21370	6.85	13.7	30	80	12	
ABES-21380	6.9	13.8	30	80	12	
ABES-21390	6.95	13.9	30	80	12	
ABES-21400	7	14.0	30	90	16	
ABES-21410	7.05	14.1	30	90	16	
ABES-21420	7.1	14.2	30	90	16	
ABES-21430	7.15	14.3	30	90	16	
ABES-21440	7.2	14.4	30	90	16	
ABES-21450	7.25	14.5	30	90	16	
ABES-21460	7.3	14.6	30	90	16	
ABES-21470	7.35	14.7	30	90	16	
ABES-21480	7.4	14.8	30	90	16	
ABES-21490	7.45	14.9	30	90	16	
ABES-21500	7.5	15.0	30	90	16	
ABES-21510	7.55	15.1	30	90	16	
ABES-21520	7.6	15.2	30	90	16	
ABES-21530	7.65	15.3	30	90	16	
ABES-21540	7.7	15.4	30	90	16	

単位 Unit : mm

型番 CODE NUMBER	R	径 φD	刃長 ℓ	全長 L	シャンク d	定価 ¥
ABES-21550	7.75	15.5	30	90	16	
ABES-21560	7.8	15.6	30	90	16	
ABES-21600	8	16.0	30	90	16	
ABES-21610	8.05	16.1	30	90	16	
ABES-21620	8.1	16.2	30	90	16	
ABES-21640	8.2	16.4	30	90	16	
ABES-21650	8.25	16.5	30	90	16	
ABES-21660	8.3	16.6	30	90	16	
ABES-21680	8.4	16.8	30	90	16	
ABES-21700	8.5	17.0	30	90	16	
ABES-21750	8.75	17.5	30	90	16	
ABES-21800	9	18.0	40	105	20	
ABES-21850	9.25	18.5	40	105	20	
ABES-21900	9.5	19.0	40	105	20	
ABES-21950	9.75	19.5	40	105	20	
ABES-22000	10	20.0	40	105	20	

型番 CODE NUMBER	R	径 φD	刃長 ℓ	全長 L	シャンク d	定価 ¥

# AMBES-2/ABES-2 2枚刃ボールエンドミル

## AMBES-2/ABES-2 2-Flute Ball End Mill

被削材 Work Materials		炭素鋼 SS材 50C Carbon Steel		合金鋼 SCM SKD Alloy Steel		調質鋼 NAK Hardened Steel		アルミ合金 Aluminium Alloy	
R Radius	刃径 Diameter	回転数 Speed (RPM)	送り Feed (mm/min)	回転数 Speed (RPM)	送り Feed (mm/min)	回転数 Speed (RPM)	送り Feed (mm/min)	回転数 Speed (RPM)	送り Feed (mm/min)
R0.1~R0.2	0.2~0.4	22,000	220	20,000	160	17,000	100	30,000	350
R0.3~R0.4	0.6~0.8	20,000	300	18,000	250	15,500	170	28,000	500
R0.5	1	19,000	400	16,500	330	14,300	260	25,000	600
R0.8	1.6	12,000	400	10,400	330	9,000	260	15,900	600
R1	2	9,500	400	8,300	330	7,100	260	12,700	600
R2	4	4,800	400	4,200	330	3,600	260	6,400	600
R3	6	3,100	400	2,700	330	2,300	260	4,200	600
R4	8	2,400	400	2,100	330	1,800	260	3,200	600
R5	10	1,900	400	1,700	330	1,400	260	2,500	600
R6	12	1,600	400	1,400	330	1,200	260	2,100	600
R7	14	1,400	400	1,200	330	1,100	260	1,800	600
R8	16	1,200	400	1,000	330	900	260	1,600	600
R9	18	1,000	400	900	330	800	260	1,400	600
R10	20	950	400	800	330	700	260	1,300	600

被削材 Work Materials		銅合金 Copper Alloy		樹脂 Resin	
R Radius	刃径 Diameter	回転数 Speed (RPM)	送り Feed (mm/min)	回転数 Speed (RPM)	送り Feed (mm/min)
R0.1~R0.2	0.2~0.4	26,000	300	27,000	300
R0.3~R0.4	0.6~0.8	24,000	400	25,000	400
R0.5	1	22,500	500	21,000	500
R0.8	1.6	13,900	500	14,900	500
R1	2	11,100	500	11,900	500
R2	4	5,600	500	6,000	500
R3	6	3,700	500	4,000	500
R4	8	2,800	500	3,000	500
R5	10	2,200	500	2,400	500
R6	12	1,900	500	2,000	500
R7	14	1,600	500	1,700	500
R8	16	1,400	500	1,500	500
R9	18	1,200	500	1,300	500
R10	20	1,100	500	1,200	500

## 備考

- 1) 機械、チャックは剛性のある精度の高いものをご使用下さい。
- 2) チャッキング時のエンドミルの振れ精度は0.01mm以下に抑えて下さい。
- 3) ご使用の機械の最高回転数が上記切削条件に達しない場合は、なるべく安定領域での高い回転数で使用し、送り速度を調整して下さい。

## Remarks:

- 1) Use a rigid and precise machine and holder.
- 2) The run out with an end mill in a spindle should be within 0.01mm.
- 3) When using low speed machines, use the maximum speed but in stable rotation range and adjust the feed rate.

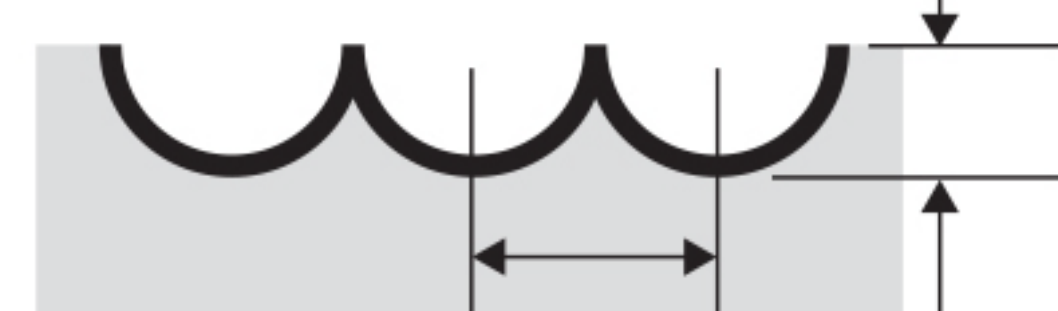
AMBES-2/ABES-2  
切り込み量 Depth of Cut0.05D (R0.1~R0.475)  
0.2D (≥R0.5)0.03D~0.05D (R0.1~R0.9)  
0.08D~0.1D (R1~R10)