

4枚刃 スクエアエンドミル

4-Flute Square End Mill

AES-4

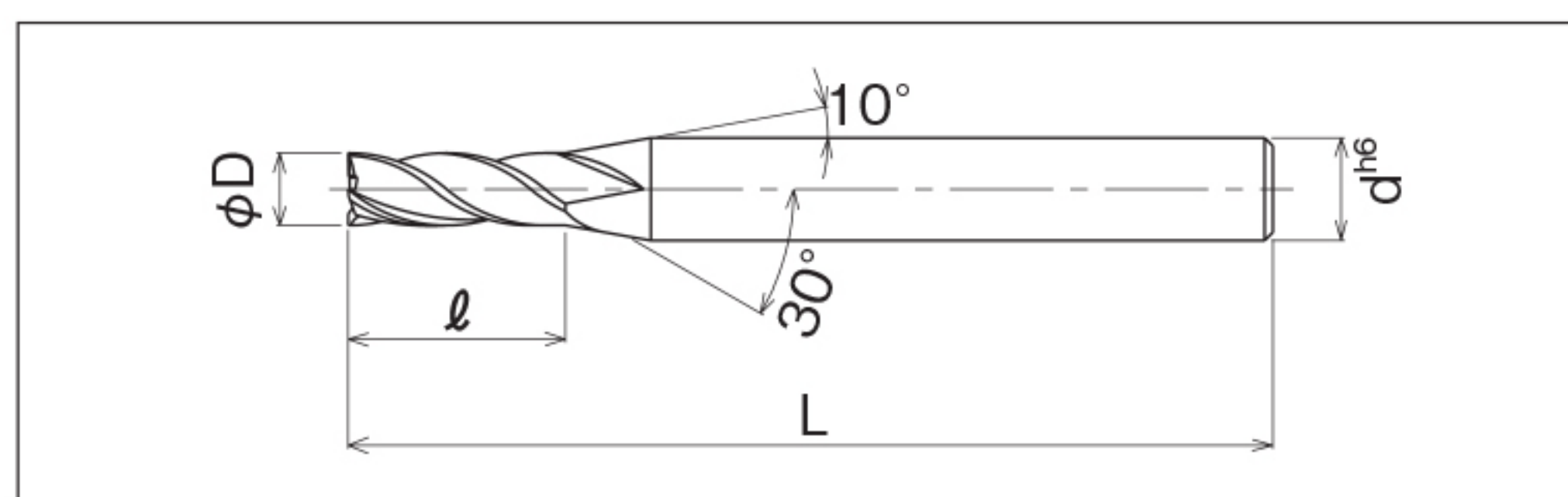

■ 一般鋼材から非鉄、樹脂まで幅広い適用が可能です。

Wide application available in work materials, from general steel to non-ferrous and resin.

■ 高剛性4枚刃で溝加工から側面加工まで対応。

Capable for both grooving and precision side milling.

外径公差：+0~-0.02

φD Tolerance



単位 Unit : mm

型番 CODE NUMBER	径 φD	刃長 ℓ	全長 L	シャンク d	定価 ¥
AES-40100	1	3	40	4	
AES-40110	1.1	3	40	4	
AES-40120	1.2	3	40	4	
AES-40130	1.3	3	40	4	
AES-40140	1.4	3	40	4	
AES-40150	1.5	5	40	4	
AES-40160	1.6	5	40	4	
AES-40170	1.7	5	40	4	
AES-40180	1.8	5	40	4	
AES-40190	1.9	5	40	4	
AES-40200	2	6	40	4	
AES-40210	2.1	6	40	4	
AES-40220	2.2	6	40	4	
AES-40230	2.3	6	40	4	
AES-40240	2.4	6	40	4	
AES-40250	2.5	8	40	4	
AES-40260	2.6	8	40	4	
AES-40270	2.7	8	40	4	
AES-40280	2.8	8	40	4	
AES-40290	2.9	8	40	4	
AES-40300	3	8	45	4	
AES-40310	3.1	8	45	4	
AES-40320	3.2	8	45	4	
AES-40330	3.3	8	45	4	
AES-40340	3.4	8	45	4	
AES-40350	3.5	10	45	4	
AES-40360	3.6	10	45	4	

型番 CODE NUMBER	径 φD	刃長 ℓ	全長 L	シャンク d	定価 ¥
AES-40370	3.7	10	45	4	
AES-40380	3.8	10	45	4	
AES-40390	3.9	10	45	4	
AES-40400	4	12	45	6	
AES-40410	4.1	12	45	6	
AES-40420	4.2	12	45	6	
AES-40430	4.3	12	45	6	
AES-40440	4.4	12	45	6	
AES-40450	4.5	12	45	6	
AES-40460	4.6	12	45	6	
AES-40470	4.7	12	45	6	
AES-40480	4.8	12	45	6	
AES-40490	4.9	12	45	6	
AES-40500	5	15	60	6	
AES-40550	5.5	15	60	6	
AES-40600	6	15	60	6	
AES-40650	6.5	15	60	6	
AES-40700	7	20	60	8	
AES-40750	7.5	20	60	8	
AES-40800	8	20	60	8	
AES-40850	8.5	20	60	8	
AES-40900	9	20	70	10	
AES-40950	9.5	20	70	10	
AES-41000	10	25	70	10	
AES-41100	11	25	75	12	
AES-41200	12	25	75	12	

AES-4 4枚刃スクエアエンドミル

AES-4 4-Flute Square End mill

被削材 Work Materials	炭素鋼 SS材 S50C Carbon Steel			合金鋼 SCM SK材 Alloy Steel			調質鋼 NAK Prehardened Steel		
	回転数 Speed (RPM)	側面 SideMilling (mm/min)	溝 Slotting (mm/min)	回転数 Speed (RPM)	側面 SideMilling (mm/min)	溝 Slotting (mm/min)	回転数 Speed (RPM)	側面 SideMilling (mm/min)	溝 Slotting (mm/min)
1	12,700	200	80	9,600	130	55	8,000	110	45
1.5	8,500	200	80	6,400	130	55	5,300	110	45
2	6,400	230	90	4,800	150	60	4,000	120	50
2.5	5,100	230	90	3,800	150	60	3,200	120	50
3	4,200	240	100	3,200	160	70	2,700	140	60
4	3,200	240	100	2,400	160	70	2,000	140	60
5	2,500	240	110	1,900	190	70	1,600	150	70
6	2,100	240	110	1,600	190	70	1,300	150	70
8	1,600	240	110	1,200	190	70	1,000	150	70
10	1,300	240	110	1,000	190	70	800	150	70
12	1,100	240	110	800	190	70	700	150	70

被削材 Work Materials	アルミ合金 Aluminium Alloy			銅合金 Copper Alloy			樹脂 Resin		
	回転数 Speed (RPM)	側面 SideMilling (mm/min)	溝 Slotting (mm/min)	回転数 Speed (RPM)	側面 SideMilling (mm/min)	溝 Slotting (mm/min)	回転数 Speed (RPM)	側面 SideMilling (mm/min)	溝 Slotting (mm/min)
1	17,500	380	240	14,300	290	120	15,900	320	140
1.5	11,700	380	240	9,600	290	120	10,600	320	140
2	8,800	450	290	7,200	340	150	8,000	380	180
2.5	7,000	450	290	5,700	340	150	6,400	380	180
3	5,800	500	320	4,800	380	170	5,300	420	200
4	4,400	500	320	3,600	380	170	4,000	420	200
5	3,500	540	350	2,900	410	180	3,200	450	210
6	2,900	540	350	2,400	410	180	2,700	450	210
8	2,200	540	350	1,800	410	180	2,000	450	210
10	1,800	540	350	1,400	410	180	1,600	450	210
12	1,500	540	350	1,200	410	180	1,300	450	210

◀ AMEL/AEI 側面加工 Side Milling

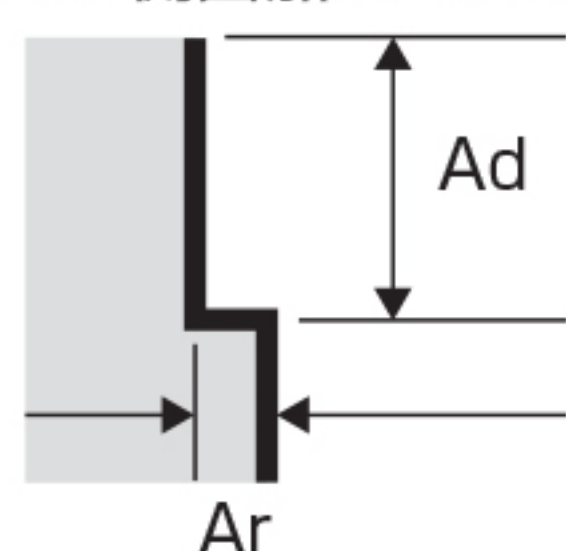

AES-4切り込み量 溝加工 Slotting
Depth of cut

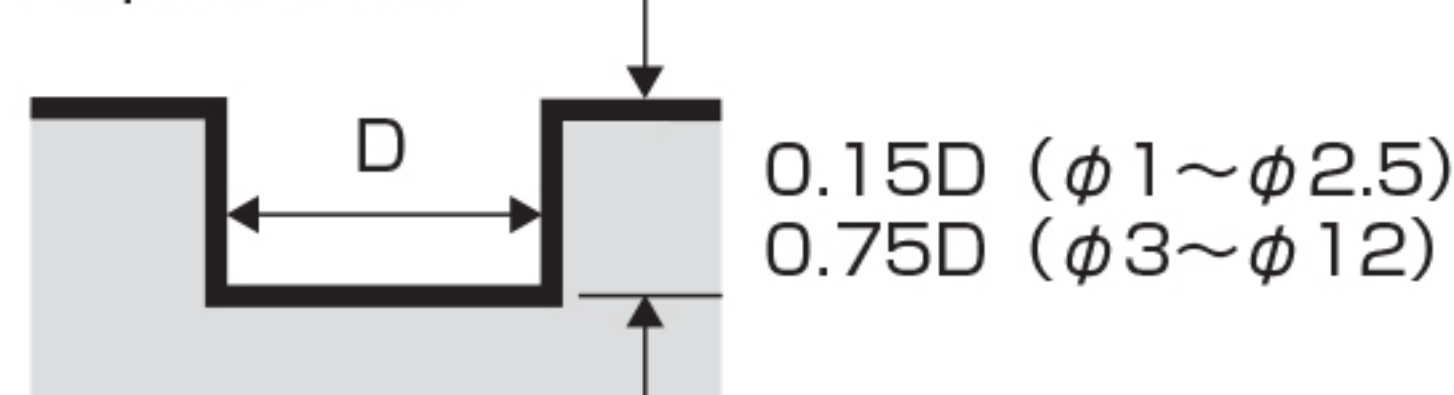

側面加工 Side Milling

