

2枚刃微小径スクエアエンドミル

2-Flute Miniature Square End Mill

AMES-2

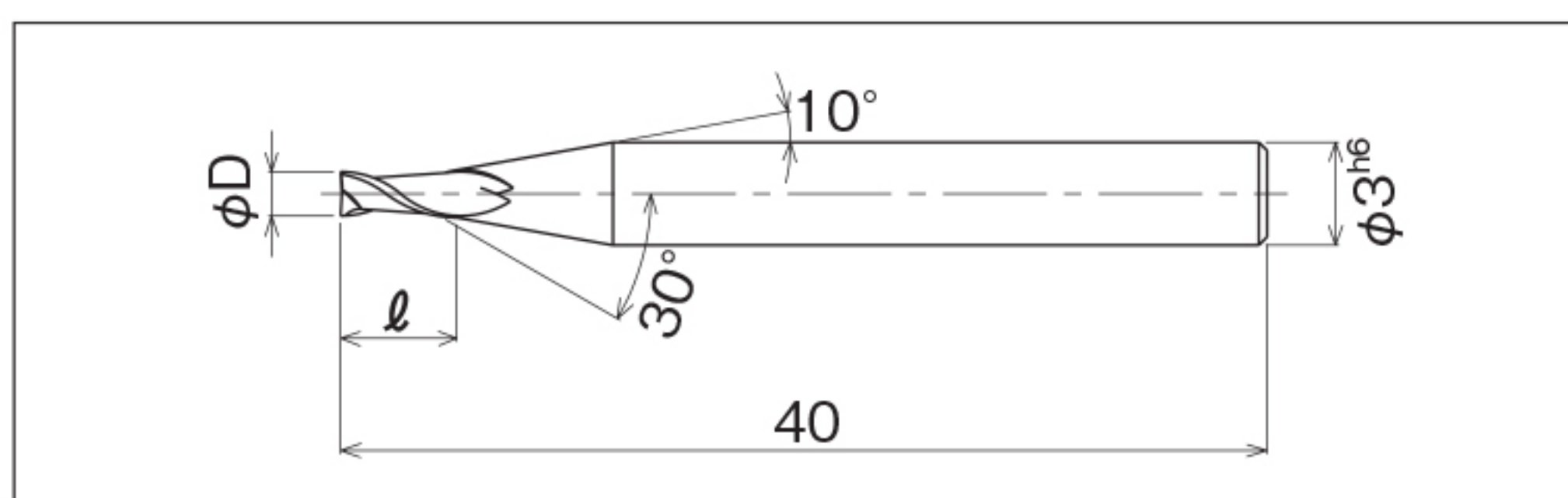

■ 精密金型、精密部品などの精度の厳しい加工に最適です。

Most suitable for precision molds and parts that requires stringent accuracy and tolerance.

■ 新たに $\phi 0.05 \sim \phi 0.09$ を標準在庫品として追加しました。

$\phi 0.05 \sim \phi 0.09$ are added as standard stock item.

外径公差：+0~-0.01

ϕD Tolerance

単位 Unit : mm

型番 CODE NUMBER	径 ϕD	刃長 ℓ	全長 L	シャンク d	定価 ¥
AMES-20005	0.05	0.1	40	3	
AMES-20006	0.06	0.1	40	3	
AMES-20007	0.07	0.15	40	3	
AMES-20008	0.08	0.15	40	3	
AMES-20009	0.09	0.15	40	3	
AMES-20010	0.1	0.2	40	3	
AMES-20015	0.15	0.3	40	3	
AMES-20020	0.2	0.4	40	3	
AMES-20025	0.25	0.5	40	3	
AMES-20030	0.3	1	40	3	
AMES-20035	0.35	1	40	3	
AMES-20040	0.4	1	40	3	
AMES-20045	0.45	1	40	3	
AMES-20050	0.5	1	40	3	
AMES-20055	0.55	1	40	3	
AMES-20060	0.6	2	40	3	
AMES-20065	0.65	2	40	3	
AMES-20070	0.7	2	40	3	
AMES-20075	0.75	2	40	3	
AMES-20080	0.8	2.5	40	3	
AMES-20085	0.85	2.5	40	3	
AMES-20090	0.9	2.5	40	3	
AMES-20095	0.95	2.5	40	3	



AMES-2/AES-2 2枚刃スクエアエンドミル

AMES-2/AES-2 2-Flute Square End mill

被削材 Work Materials	炭素鋼 SS材 S50C Carbon Steel			合金鋼 SCM SK材 Alloy Steel			調質鋼 NAK Prehardened Steel		
	回転数 Speed (RPM)	側面 SideMilling (mm/min)	溝 Slotting (mm/min)	回転数 Speed (RPM)	側面 SideMilling (mm/min)	溝 Slotting (mm/min)	回転数 Speed (RPM)	側面 SideMilling (mm/min)	溝 Slotting (mm/min)
0.1~0.3	20,000	20~50	10~20	15,000	15~35	7~15	12,000	12~30	5~13
0.4~0.5	15,000	70~80	30~35	11,300	50~55	20~25	10,000	40~45	20~30
0.8	13,000	100	40	10,000	70	30	8,500	50	20
1	12,700	130	50	9,600	90	35	8,000	70	30
1.5	8,500	130	50	6,400	90	35	5,300	70	30
2	6,400	150	60	4,800	100	40	4,000	80	35
2.5	5,100	150	60	3,800	100	40	3,200	80	35
3	4,200	160	65	3,200	110	45	2,700	90	40
4	3,200	160	65	2,400	110	45	2,000	90	40
5	2,500	180	70	1,900	130	45	1,600	100	45
6	2,100	180	70	1,600	130	45	1,300	100	45
8	1,600	180	70	1,200	130	45	1,000	100	45
10	1,300	180	70	1,000	130	45	800	100	45
12	1,100	180	70	800	130	45	700	100	45

被削材 Work Materials	アルミ合金 Aluminium Alloy			銅合金 Copper Alloy			樹脂 Resin		
	回転数 Speed (RPM)	側面 SideMilling (mm/min)	溝 Slotting (mm/min)	回転数 Speed (RPM)	側面 SideMilling (mm/min)	溝 Slotting (mm/min)	回転数 Speed (RPM)	側面 SideMilling (mm/min)	溝 Slotting (mm/min)
0.1~0.3	25,000	100	40	20,000	70	30	20,000	90	40
0.4~0.5	20,000	150	60	18,000	100	40	18,000	130	50
0.8	18,000	200	60	15,000	150	70	17,000	170	75
1	17,500	250	100	14,300	190	80	15,900	210	95
1.5	11,700	250	100	9,600	190	80	10,600	210	95
2	8,800	300	120	7,200	230	100	8,000	250	120
2.5	7,000	300	120	5,700	230	100	6,400	250	120
3	5,800	330	140	4,800	250	110	5,300	280	130
4	4,400	330	140	3,600	250	110	4,000	280	130
5	3,500	360	150	2,900	270	120	3,200	300	140
6	2,900	360	150	2,400	270	120	2,700	300	140
8	2,200	360	150	1,800	270	120	2,000	300	140
10	1,800	360	150	1,400	270	120	1,600	300	140
12	1,500	360	150	1,200	270	120	1,300	300	140

AMES-2/AES-2切り込み量 Depth of cut

側面加工 Side Milling

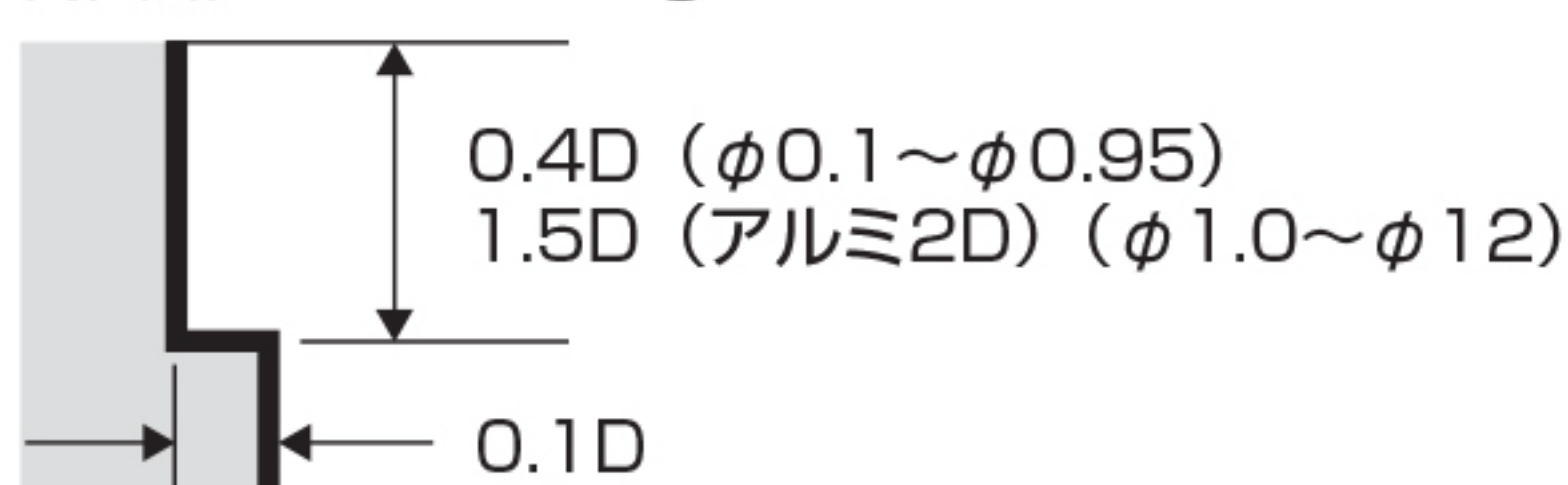

溝加工 Slotting

