

# ルーマドリル 標準刃長

Micro Drill Regular Flute Length

## ADR

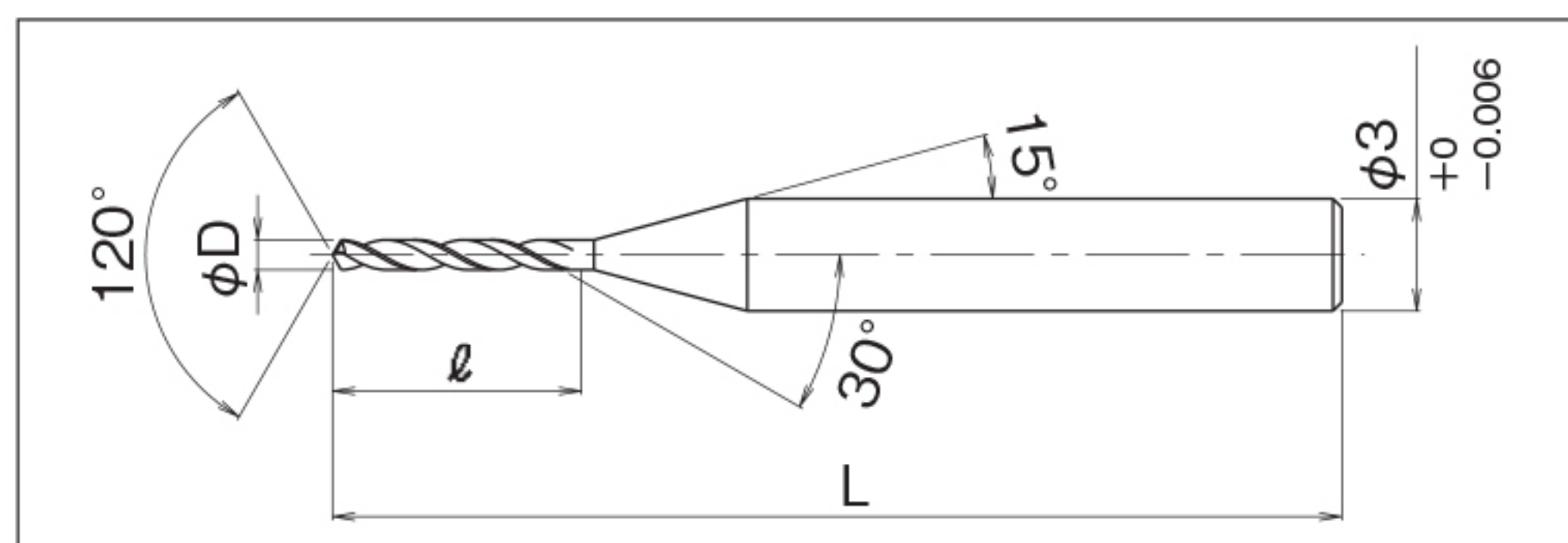

φ0.02~φ0.04は首逃げ2段形状です。

■ 精密・多孔細穴加工用ドリルです。(最小径φ0.02)

Best for drilling precision small holes (smallest diameter φ0.02)

■ 一般鋼材から非鉄、樹脂まで幅広い適用が可能です。

Wide application available in work materials, covering from steel to non-ferrous and resin.

刃径公差：+0~-0.005

φD Tolerance



単位 Unit : mm

型番 CODE NUMBER	径 φD	刃長 ℓ	全長 L	シャンク d	定価 ¥
ADR-0002	0.02	0.2	38	3	
ADR-0003	0.03	0.3	38	3	
ADR-0004	0.04	0.4	38	3	
ADR-0005	0.05	0.5	38	3	
ADR-0006	0.06	0.6	38	3	
ADR-0007	0.07	0.7	38	3	
ADR-0008	0.08	0.8	38	3	
ADR-0009	0.09	0.9	38	3	
ADR-0010	0.1	1.2	38	3	
ADR-0011	0.11	1.2	38	3	
ADR-0012	0.12	1.4	38	3	
ADR-0013	0.13	1.4	38	3	
ADR-0014	0.14	1.4	38	3	
ADR-0015	0.15	1.8	38	3	
ADR-0016	0.16	1.8	38	3	
ADR-0017	0.17	1.8	38	3	
ADR-0018	0.18	2.1	38	3	
ADR-0019	0.19	2.1	38	3	
ADR-0020	0.2	2.4	38	3	
ADR-0021	0.21	2.4	38	3	
ADR-0022	0.22	2.6	38	3	
ADR-0023	0.23	2.6	38	3	
ADR-0024	0.24	2.6	38	3	
ADR-0025	0.25	3	38	3	
ADR-0026	0.26	3	38	3	
ADR-0027	0.27	3	38	3	

型番 CODE NUMBER	径 φD	刃長 ℓ	全長 L	シャンク d	定価 ¥
ADR-0028	0.28	3.3	38	3	
ADR-0029	0.29	3.3	38	3	
ADR-0030	0.3	5	38	3	
ADR-0031	0.31	5	38	3	
ADR-0032	0.32	5	38	3	
ADR-0033	0.33	5	38	3	
ADR-0034	0.34	5	38	3	
ADR-0035	0.35	5	38	3	
ADR-0036	0.36	5	38	3	
ADR-0037	0.37	5	38	3	
ADR-0038	0.38	5	38	3	
ADR-0039	0.39	5	38	3	
ADR-0040	0.4	6	38	3	
ADR-0041	0.41	6	38	3	
ADR-0042	0.42	6	38	3	
ADR-0043	0.43	6	38	3	
ADR-0044	0.44	6	38	3	
ADR-0045	0.45	6	38	3	
ADR-0046	0.46	6	38	3	
ADR-0047	0.47	6	38	3	
ADR-0048	0.48	6	38	3	
ADR-0049	0.49	6	38	3	
ADR-0050	0.5	6	38	3	
ADR-0051	0.51	6	38	3	
ADR-0052	0.52	6	38	3	
ADR-0053	0.53	6	38	3	



単位 Unit : mm

型番 CODE NUMBER	径 φD	刃長 ℓ	全長 L	シャンク d	定価 ¥
ADR-0054	0.54	6	38	3	
ADR-0055	0.55	6	38	3	
ADR-0056	0.56	6	38	3	
ADR-0057	0.57	6	38	3	
ADR-0058	0.58	6	38	3	
ADR-0059	0.59	6	38	3	
ADR-0060	0.6	7	38	3	
ADR-0061	0.61	7	38	3	
ADR-0062	0.62	7	38	3	
ADR-0063	0.63	7	38	3	
ADR-0064	0.64	7	38	3	
ADR-0065	0.65	7	38	3	
ADR-0066	0.66	7	38	3	
ADR-0067	0.67	7	38	3	
ADR-0068	0.68	7	38	3	
ADR-0069	0.69	7	38	3	
ADR-0070	0.7	8	38	3	
ADR-0071	0.71	8	38	3	
ADR-0072	0.72	8	38	3	
ADR-0073	0.73	8	38	3	
ADR-0074	0.74	8	38	3	
ADR-0075	0.75	8	38	3	
ADR-0076	0.76	8	38	3	
ADR-0077	0.77	8	38	3	
ADR-0078	0.78	8	38	3	
ADR-0079	0.79	8	38	3	
ADR-0080	0.8	8	38	3	
ADR-0081	0.81	8	38	3	
ADR-0082	0.82	8	38	3	
ADR-0083	0.83	8	38	3	
ADR-0084	0.84	8	38	3	
ADR-0085	0.85	8	38	3	
ADR-0086	0.86	8	38	3	
ADR-0087	0.87	8	38	3	
ADR-0088	0.88	8	38	3	
ADR-0089	0.89	8	38	3	
ADR-0090	0.9	8	38	3	
ADR-0091	0.91	8	38	3	
ADR-0092	0.92	8	38	3	
ADR-0093	0.93	8	38	3	
ADR-0094	0.94	8	38	3	
ADR-0095	0.95	8	38	3	
ADR-0096	0.96	8	38	3	
ADR-0097	0.97	8	38	3	

型番 CODE NUMBER	径 φD	刃長 ℓ	全長 L	シャンク d	定価 ¥
ADR-0098	0.98	8	38	3	
ADR-0099	0.99	8	38	3	
ADR-0100	1	10	38	3	
ADR-0101	1.01	10	38	3	
ADR-0102	1.02	10	38	3	
ADR-0103	1.03	10	38	3	
ADR-0104	1.04	10	38	3	
ADR-0105	1.05	10	38	3	
ADR-0106	1.06	10	38	3	
ADR-0107	1.07	10	38	3	
ADR-0108	1.08	10	38	3	
ADR-0109	1.09	10	38	3	
ADR-0110	1.1	10	38	3	
ADR-0111	1.11	10	38	3	
ADR-0112	1.12	10	38	3	
ADR-0113	1.13	10	38	3	
ADR-0114	1.14	10	38	3	
ADR-0115	1.15	10	38	3	
ADR-0116	1.16	10	38	3	
ADR-0117	1.17	10	38	3	
ADR-0118	1.18	10	38	3	
ADR-0119	1.19	10	38	3	
ADR-0120	1.2	10	38	3	
ADR-0121	1.21	10	38	3	
ADR-0122	1.22	10	38	3	
ADR-0123	1.23	10	38	3	
ADR-0124	1.24	10	38	3	
ADR-0125	1.25	10	38	3	
ADR-0126	1.26	10	38	3	
ADR-0127	1.27	10	38	3	
ADR-0128	1.28	10	38	3	
ADR-0129	1.29	10	38	3	
ADR-0130	1.3	10	38	3	
ADR-0131	1.31	10	38	3	
ADR-0132	1.32	10	38	3	
ADR-0133	1.33	10	38	3	
ADR-0134	1.34	10	38	3	
ADR-0135	1.35	10	38	3	
ADR-0136	1.36	10	38	3	
ADR-0137	1.37	10	38	3	
ADR-0138	1.38	10	38	3	
ADR-0139	1.39	10	38	3	
ADR-0140	1.4	10	38	3	
ADR-0141	1.41	10	38	3	



型番 CODE NUMBER	径 φD	刃長 ℓ	全長 L	シャンク d	定価 ¥
ADR-0142	1.42	10	38	3	
ADR-0143	1.43	10	38	3	
ADR-0144	1.44	10	38	3	
ADR-0145	1.45	10	38	3	
ADR-0146	1.46	10	38	3	
ADR-0147	1.47	10	38	3	
ADR-0148	1.48	10	38	3	
ADR-0149	1.49	10	38	3	
ADR-0150	1.5	10	38	3	
ADR-0151	1.51	10	38	3	
ADR-0152	1.52	10	38	3	
ADR-0153	1.53	10	38	3	
ADR-0154	1.54	10	38	3	
ADR-0155	1.55	10	38	3	
ADR-0156	1.56	10	38	3	
ADR-0157	1.57	10	38	3	
ADR-0158	1.58	10	38	3	
ADR-0159	1.59	10	38	3	
ADR-0160	1.6	22	50	3	
ADR-0161	1.61	22	50	3	
ADR-0162	1.62	22	50	3	
ADR-0163	1.63	22	50	3	
ADR-0164	1.64	22	50	3	
ADR-0165	1.65	22	50	3	
ADR-0166	1.66	22	50	3	
ADR-0167	1.67	22	50	3	
ADR-0168	1.68	22	50	3	
ADR-0169	1.69	22	50	3	
ADR-0170	1.7	22	50	3	
ADR-0171	1.71	22	50	3	
ADR-0172	1.72	22	50	3	
ADR-0173	1.73	22	50	3	
ADR-0174	1.74	22	50	3	
ADR-0175	1.75	22	50	3	
ADR-0176	1.76	22	50	3	
ADR-0177	1.77	22	50	3	
ADR-0178	1.78	22	50	3	
ADR-0179	1.79	22	50	3	
ADR-0180	1.8	22	50	3	
ADR-0181	1.81	22	50	3	
ADR-0182	1.82	22	50	3	
ADR-0183	1.83	22	50	3	
ADR-0184	1.84	22	50	3	
ADR-0185	1.85	22	50	3	

型番 CODE NUMBER	径 φD	刃長 ℓ	全長 L	シャンク d	定価 ¥
ADR-0186	1.86	22	50	3	
ADR-0187	1.87	22	50	3	
ADR-0188	1.88	22	50	3	
ADR-0189	1.89	22	50	3	
ADR-0190	1.9	22	50	3	
ADR-0191	1.91	22	50	3	
ADR-0192	1.92	22	50	3	
ADR-0193	1.93	22	50	3	
ADR-0194	1.94	22	50	3	
ADR-0195	1.95	22	50	3	
ADR-0196	1.96	22	50	3	
ADR-0197	1.97	22	50	3	
ADR-0198	1.98	22	50	3	
ADR-0199	1.99	22	50	3	
ADR-0200	2	22	50	3	
ADR-0201	2.01	22	50	3	
ADR-0202	2.02	22	50	3	
ADR-0203	2.03	22	50	3	
ADR-0204	2.04	22	50	3	
ADR-0205	2.05	22	50	3	
ADR-0206	2.06	22	50	3	
ADR-0207	2.07	22	50	3	
ADR-0208	2.08	22	50	3	
ADR-0209	2.09	22	50	3	
ADR-0210	2.1	22	50	3	
ADR-0211	2.11	22	50	3	
ADR-0212	2.12	22	50	3	
ADR-0213	2.13	22	50	3	
ADR-0214	2.14	22	50	3	
ADR-0215	2.15	22	50	3	
ADR-0216	2.16	22	50	3	
ADR-0217	2.17	22	50	3	
ADR-0218	2.18	22	50	3	
ADR-0219	2.19	22	50	3	
ADR-0220	2.2	22	50	3	
ADR-0221	2.21	22	50	3	
ADR-0222	2.22	22	50	3	
ADR-0223	2.23	22	50	3	
ADR-0224	2.24	22	50	3	
ADR-0225	2.25	22	50	3	
ADR-0226	2.26	22	50	3	
ADR-0227	2.27	22	50	3	
ADR-0228	2.28	22	50	3	
ADR-0229	2.29	22	50	3	







# ADR/ADRS/ADRSL/ADRL/ADR-SP/AMSD ルーマ型ドリルシリーズ

## Micro Drill with Common Shank Series

被削材 Work Materials	炭素鋼・合金鋼・工具鋼 Steel						ステンレス Stainless Steel			
	炭素鋼 Carbon steel SS S50C		合金鋼 Alloy Steel SCM SKS		調質鋼 Hardened Steel NAK SKD (HRC30~38)		SUS304等 オーステナイト系 SUS304/316 Austenitic		マルテンサイト・ フェライト系 SUS420/430 Martensitic & Ferritic	
条件 先端径	回転数 Rotation (min <sup>-1</sup> )	送り量 Feed (mm/rev)	回転数 Rotation (min <sup>-1</sup> )	送り量 Feed (mm/rev)	回転数 Rotation (min <sup>-1</sup> )	送り量 Feed (mm/rev)	回転数 Rotation (min <sup>-1</sup> )	送り量 Feed (mm/rev)	回転数 Rotation (min <sup>-1</sup> )	送り量 Feed (mm/rev)
φ0.02~ 0.09	10,000→ 20,000	0.001~ 0.0015	10,000→ 20,000	0.001~ 0.0015	10,000→ 20,000	0.001	10,000→ 20,000	0.0005~ 0.001	10,000→ 20,000	0.001~ 0.0015
φ0.1~ 0.29	19,000~ 13,000	0.002~ 0.01	16,000~ 11,000	0.0014~ 0.007	13,000~ 8,800	0.001~ 0.004	10,000~ 5,000	0.0005~ 0.001	13,000~ 8,800	0.0005~ 0.001
φ0.3~ 0.49	13,000~ 12,000	0.01~ 0.02	11,000~ 9,700	0.007~ 0.01	8,800~ 6,500	0.003~ 0.005	5,000~ 4,500	0.001~ 0.005	8,800~ 6,500	0.001~ 0.005
φ0.5~ 0.99	12,000~ 9,600	0.02~ 0.04	9,700~ 6,400	0.01~ 0.02	6,500~ 4,800	0.005~ 0.01	4,500~ 3,200	0.005~ 0.01	6,500~ 4,800	0.005~ 0.01
φ1~ 1.99	9,600~ 6,400	0.03~ 0.06	6,400~ 4,000	0.02~ 0.05	3,100~ 2,400	0.01~ 0.03	3,200~ 2,400	0.01~ 0.03	4,800~ 3,200	0.01~ 0.03
φ2.0~ 3.0	6,400~ 4,200	0.07~ 0.1	4,000~ 3,200	0.05~ 0.08	2,400~ 1,600	0.02~ 0.04	2,400~ 1,800	0.03~ 0.05	3,200~ 2,100	0.03~ 0.05

被削材 Work Materials	非鉄金属 Non-Ferrous				樹脂 Resin	
	アルミ合金 Aluminium Alloy		銅合金 Copper Alloy		エンプラ Engineering Plastic	
条件 先端径	回転数 Rotation (min <sup>-1</sup> )	送り量 Feed (mm/rev)	回転数 Rotation (min <sup>-1</sup> )	送り量 Feed (mm/rev)	回転数 Rotation (min <sup>-1</sup> )	送り量 Feed (mm/rev)
φ0.02~ 0.09	10,000→ 30,000	0.001~ 0.003	10,000→ 20,000	0.001~ 0.005	10,000→ 20,000	0.001~ 0.003
φ0.1~ 0.29	22,200~ 16,500	0.005~ 0.02	16,000~ 11,000	0.002~ 0.008	20,000~ 15,000	0.005~ 0.01
φ0.3~ 0.49	16,500~ 13,000	0.02~ 0.04	11,000~ 11,500	0.008~ 0.015	15000	0.01~ 0.02
φ0.5~ 0.99	13,000~ 12,700	0.04~ 0.06	11,500~ 9,600	0.015~ 0.04	15,000~ 10,000	0.02~ 0.04
φ1~ 1.99	12,700~ 6,400	0.06~ 0.12	9,600~ 4,800	0.04~ 0.08	10,000~ 6,000	0.05~ 0.07
φ2.0~ 3.0	6,400~ 5,300	0.12~ 0.2	4,800~ 4,200	0.08~ 0.15	6,000~ 5,000	0.07~ 0.1

- ▶ **ステップ送り量:** φ0.02~φ0.4: ドリル径 × 10% (0.1D)  
**Step Feed** φ0.5~φ1.0: ドリル径 × 20% (0.2D)  
φ1.0 以上: ドリル径 × 25% ~ 50% (0.25~0.5D)

**備考**

- 1) 細穴、特にφ1.0以下の穴あけ加工の場合には、ガイド穴（センター穴）を施した上で穴加工を行って下さい。  
ドリル食い付き時の破損・チッピングを防ぎます。
- 2) チャッキング時のドリル振れ精度は0.003mm以下に抑えて下さい。
- 3) ご使用の機械の最高回転数が上記切削条件に達しない場合は、なるべく安定領域での高い回転数でご使用下さい。  
その場合送り量も同じ比率で下げて下さい。
- 4) ドリルφ0.5以下で使用の場合は、上記切削条件よりもご使用のスピンドル精度が最も安定する回転数を優先させて下さい。

**Remarks:**

- 1) When drilling smaller hole, especially under φ1.0mm, the guide hole (positioning by starting drill) is necessary.  
It prevents the drill breakage and initial chipping of cutting edge.
- 2) The run out with a drill in a spindle should be minimized to less than 0.003mm.

- 3) When machines can not achieve a recommended rotation speed, please set maximum speed but in stable rotation range and adjust the feed rate.
- 4) For smaller drills under φ0.5, the most stable rotation speed of actually using spindle has priority over the recommended conditions indicated in the table.